

# Power of Impedance Analyzer, Comparison to Network Analyzer

Uncover real characteristics

# Table of Contents

Introduction.....	3
Necessity of Real-Characteristics Evaluation .....	3
Characteristics of Components .....	4
Characteristics of Circuits/Components on PCB .....	5
Characteristics of Materials.....	6
Characteristics of On-Wafer.....	6
Impedance Measurement Capabilities for Measuring Real-Characteristics.....	7
Impedance Measurement Instruments .....	7
Keysight’s Impedance Analyzers Specifications.....	8
Comparison of Measurement Capabilities .....	9
Conclusion.....	24
Additional Information .....	24

# Introduction

Keysight's impedance analyzers are the only instruments on the market that can provide unparalleled accuracy for component evaluation from mΩ to MΩ and from 20 Hz to 3 GHz frequency range. Uncover real characteristics of high-quality components. This application note describes why real-characteristics evaluation is essential and how to achieve real-characteristics measurements using impedance analyzer.

## Necessity of Real-Characteristics Evaluation

The real characteristics in this document mean characteristics of electrical devices, materials and components under actual conditions such as frequency, signal level, DC bias and temperature. Characteristics should be known reliably and accurately. Although the components meet manufacturer's specifications, they exhibit different characteristics when they are integrated in a circuit. The problems are sometimes due to the fact that the test conditions of the standard specifications offered by the manufacturer do not correspond to the actual operating conditions under which the part is used. In addition, characteristics that are not covered in the specifications often influence the performance of the circuit and may be unknowingly relied upon for proper operation. In most cases, due to the inflexibility of the measurement system, the conditions under which components are tested and selected are different from the conditions when the components are in operation.

To design a high-quality circuit, the characteristics of its components and printed circuit boards (PCBs) under actual operating conditions must be known. That is, the characteristics of components and PCBs depend on the conditions (frequency, signal level, temperature, etc.) under which they are used or measured. For manufacturers of electronic devices or components, it is necessary to evaluate the materials or components used in their products under actual operating conditions.



Figure 1. E4990A Impedance analyzers and test fixtures    Figure 2. E4991B Impedance analyzers and test fixtures

# Characteristics of Components

Generally, the performance of an electronic circuit depends on key components used. It is important to select proper components for meeting the circuit performance. For instance, in a voltage-controlled oscillator (VCO) circuit design when using an inductance-capacitance (LC) oscillating circuit system, the Q value of inductor used influences the phase noise performance of the oscillation. If Q value is decreased (degraded), the noise level of the oscillation output will increase (phase noise will increase).

Since Q value of an inductor changes with frequency, it is necessary to measure the characteristic in actual oscillating frequency.

A mechanical resonator (crystal resonator, ceramic resonator, SAW resonator etc.) is also used for a VCO circuit. Since oscillating frequency and the frequency variable range are dependent on the resonator used, the actual property evaluation of the resonator is necessary.

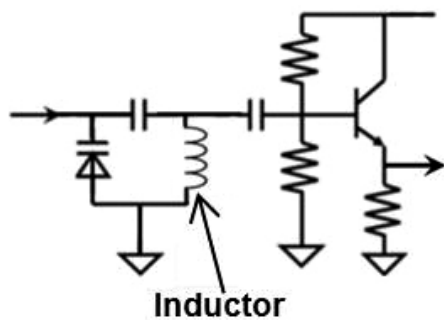

Figure 3. VCO circuit

## Required measurement performance

- Accurate Q measurement for inductor
- Wide impedance range for resonators (up to several M $\Omega$ )

# Characteristics of Circuits/Components on PCB

While characterization of components under actual operating conditions is essential for circuit design, it is also critical in R&D and QA to characterize the circuit itself operating over a wide frequency range.

When designing an electronic circuit, basic circuit blocks, such as an amplifier or filter circuit, are designed first, and then the whole circuit is assembled. In order to shorten the development-cycle time, the characteristics of each circuit block can be evaluated before the circuit is assembled. Evaluation of the input and output impedance of each circuit block, or component, is very important since the impedance between these basic circuit blocks should be well understood and matched. The characteristics of pattern inductance and stray capacitance between patterns of PCB under actual operating conditions must be known.

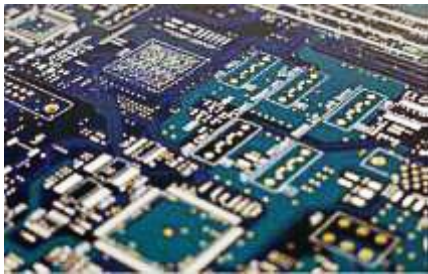

Figure 4. Circuits on PCB

## Required measurement performance

- Easy to contact various components/circuit blocks mounted on a printed circuit and accurate measurements over a wide impedance range
- Wide impedance range due to very small pattern inductance and stray capacitance (1  $\Omega$  to 1 M $\Omega$ )

# Characteristics of Materials

Due to increasing circuit complexity, density, and bit rate, relative complex permittivity (permittivity and loss tangent) of PCB's and substrate material is a critical parameter that affects circuit performance. The permittivity measurement of a PCB under actual operating conditions is necessary.

For manufacturers of electronic devices or components, it is required to evaluate accurately the materials or components used in their products under actual operating conditions such as frequency and temperature.

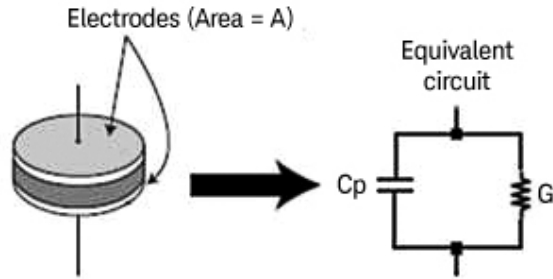

Figure 5. Parallel plate method for dielectric material

## Required measurement performance

- Accurate permittivity measurements of thin sheet-material (Accurate high impedance measurements)
- Accurate permeability measurements of magnetic material (Accurate low impedance measurements)
- Simple operation (reduce the calculation using physical size of the sample) (Direct readouts of permittivity/permeability)

# Characteristics of On-Wafer

Parameters such as the capacitance of the oxide layer ( $C_{ox}$ ) and the density of substrate impurities ( $N_{sub}$ ), are required for evaluation during the manufacturing process of MOS type semiconductors and can be derived by using measured C-V characteristics. Precise C-V measurements are required to make an accurate evaluation of these parameters.

Characteristics of components such as capacitors, inductors and MEMS devices on wafer are also measured under actual operating conditions.

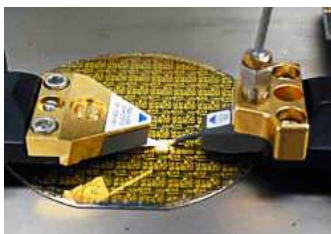

Figure 6. On-wafer measurement

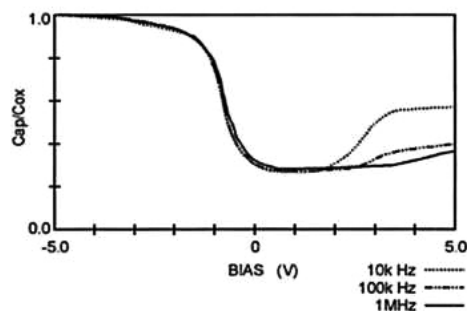

Figure 7. C-V characteristics of a semiconductor

### Required measurement performance

- Very low capacitance needs to be measured with high accuracy (a low pF, and 1 fF resolution)
- Accurate DC bias setting (0.1% and 1 mV resolution)
- Low inductance (nH range)
- Reduce additional errors caused by cable extensions and probers

## Impedance Measurement Capabilities for Measuring Real-Characteristics

To achieve accurate impedance characterization, the following capabilities are required.

- Accurate high/low impedance measurements (1Ω to MΩ range)
- Accurate high-Q/low loss measurements
- High stability measurements

## Impedance Measurement Instruments

Product type	Model	Measurement method	Advantages	Disadvantages
Impedance analyzer	E4990A	Auto-balancing bridge method	<ul style="list-style-type: none"><li>• High accuracy over a wide impedance range</li><li>• High stability measurement</li></ul>	<ul style="list-style-type: none"><li>• High frequency ranges not available</li></ul>
Impedance analyzer	E4991B	RF I-V method	<ul style="list-style-type: none"><li>• High accuracy over a wide impedance range at high frequency</li><li>• High stability measurement</li></ul>	<ul style="list-style-type: none"><li>• Operating frequency range is limited by transformer used in test head</li></ul>
Vector network analyzer	E5061B	Network analysis method	<ul style="list-style-type: none"><li>• Wide frequency range</li><li>• High-speed measurement</li></ul>	<ul style="list-style-type: none"><li>• Narrow impedance measurement range</li><li>• Recalibration required when the measurement frequency is changed</li></ul>

Table 1. Common analyzers for impedance measurements

Auto-balancing bridge method or RF I-V method provides the impedance measurement capabilities for measuring real-characteristics. The auto-balancing bridge and RF I-V methods are based on the linear relationship of the voltage-current ratio to impedance, as given by ohm's law. Thus, the theoretical impedance measurement sensitivity is constant and, it achieves high accuracy over a wide impedance range. The excellent measurement stability of the E4990A/E4991B impedance analyzer is achieved by the receiver section which is multiplexed to avoid tracking errors. In contrast, the network analysis method which measures the reflection coefficient of the DUT has a narrow accurate impedance measurement range (at  $Z_x = Z_o$ ) due to a limited impedance measurement sensitivity. To take advantage of measurement speed, a receiver multiplexed is not used in the network analysis method.

# Keysight's Impedance Analyzers Specifications

## E4990A

- Frequency range: 20 Hz to 120 MHz (E4990A Option 120)
- Basic accuracy: 0.08%
- Z-range (10% accuracy): 25 mΩ to 40 MΩ
- Built-in DC bias: 0 V to ± 40 V, 0 A to ± 100 mA

## E4991B

- Frequency range: 1 MHz to 3 GHz (E4991B Option 300)
- Basic accuracy 0.65%
- Z-range (10% accuracy): 120 mΩ to 52 kΩ
- Built-in DC bias (Option 001): 0 V to ± 40 V, 0 A to ± 100 mA

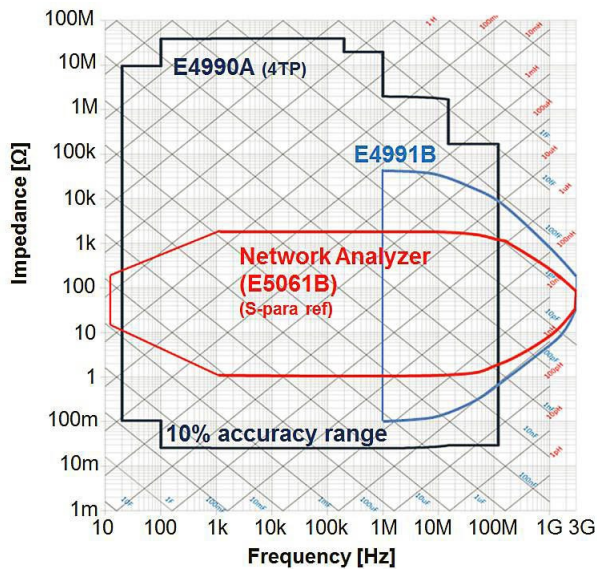

Figure 8. 10% impedance accuracy range of E4990A/E4991B/E5061B



# Comparison of Measurement Capabilities

To see the difference in practical measurement capabilities, let's compare the of measurements results using an impedance analyzer and a network analyzer.

## High impedance measurements

A 10 pF SMD capacitor at 20 Hz to 120 MHz, a typical impedance shown by the dashed line in figure 9 is measured with an E4990A impedance analyzer and network analyzer. The reactance ( $1/\omega C$ ) increases at a low frequency. Therefore, the impedance of the 10 pF capacitor also increases at a low frequency. This section focuses on the high impedance measurement capability of the E4990A and network analyzer.

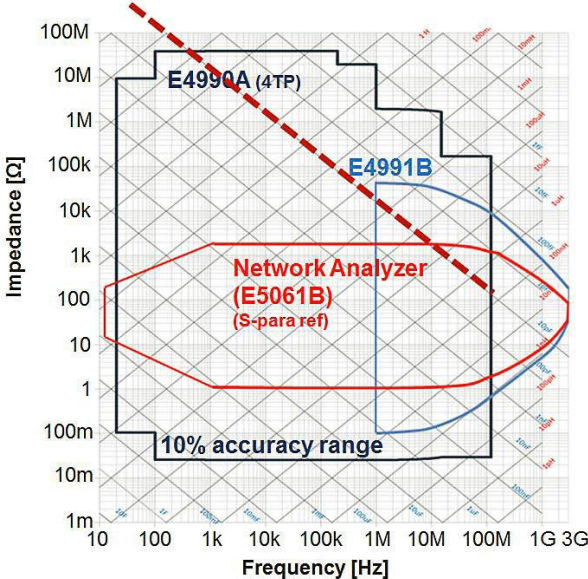
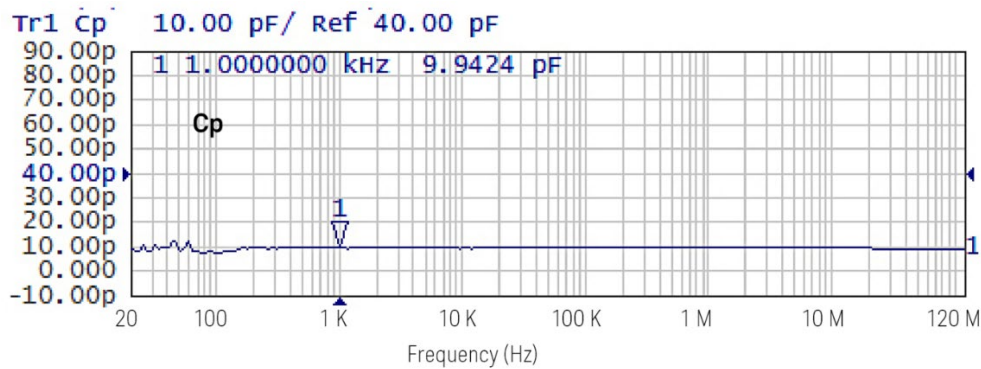
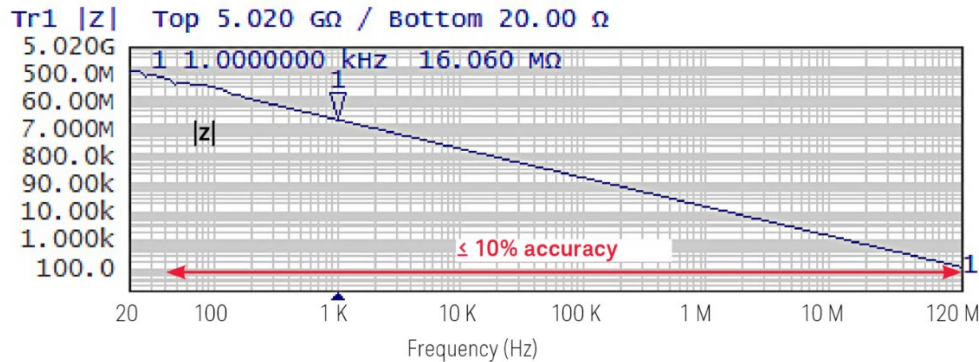

Figure 9. Frequency characteristics of a 10 pF capacitor

Figure 10 shows the measurement results for  $|Z|$  and  $C_p$  using the E4990A and network analyzer for the 10 pF capacitor. The E4990A can accurately measure the high impedance of the 10pF capacitor. The measurement accuracy of the E4990A is 10% or less when measuring the impedance of the 10pF capacitor through most of the frequency range.

$|Z|$  &  $C_p$  measurements of E4990A impedance analyzer



$|Z|$  &  $C_p$  measurements of network analyzer

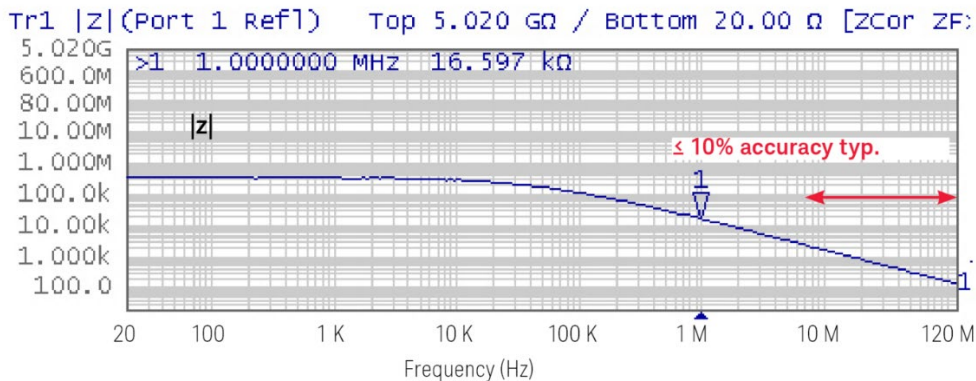

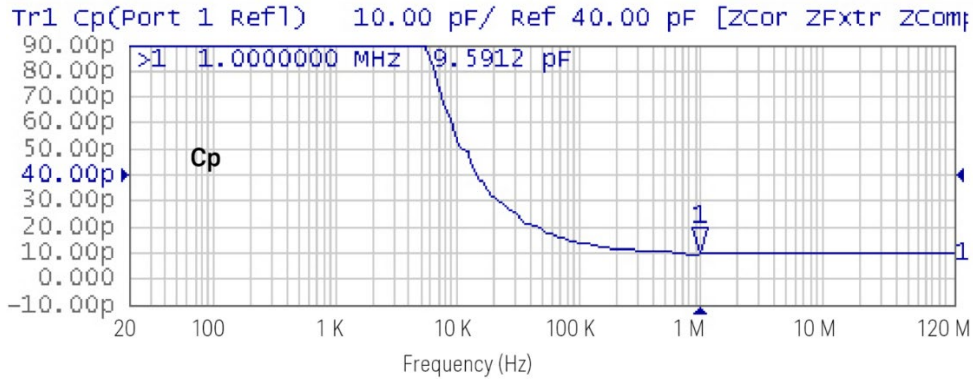

Figure 10. Measurement results example using the E4990A and network analyzer

## Low impedance measurement

A 22 nH SMD inductor at 20 Hz to 120 MHz, a typical impedance is shown by the dashed line in figure 11 and is measured using the E4990A and network analyzer. The reactance ( $\omega L$ ) decreases at low frequency, and the minimum impedance is determined by the resistance ( $R_s$ ) of winding. Therefore, the impedance of the 22 nH inductor will decrease at a low frequency as well. This section focuses on the low impedance measurement capability of the E4990A and network analyzer.

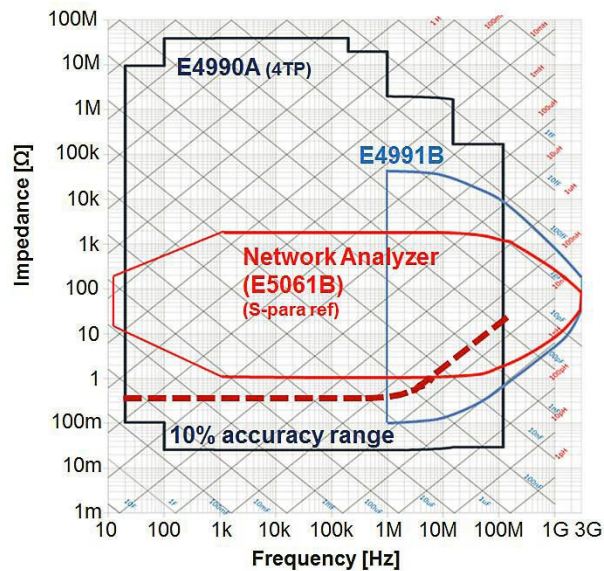
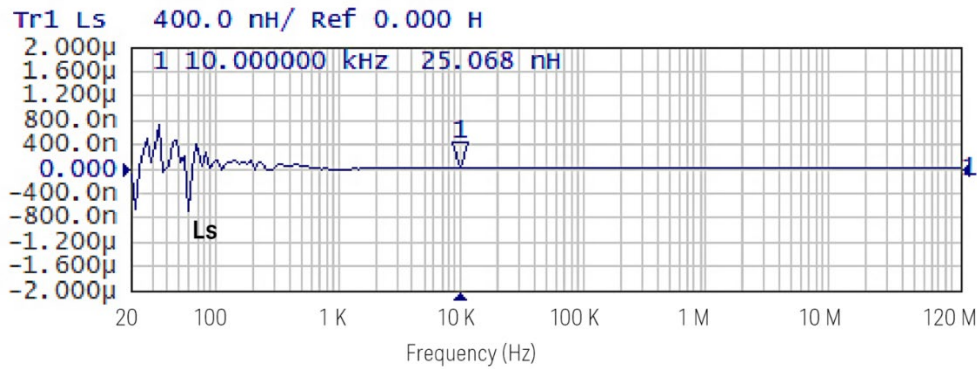
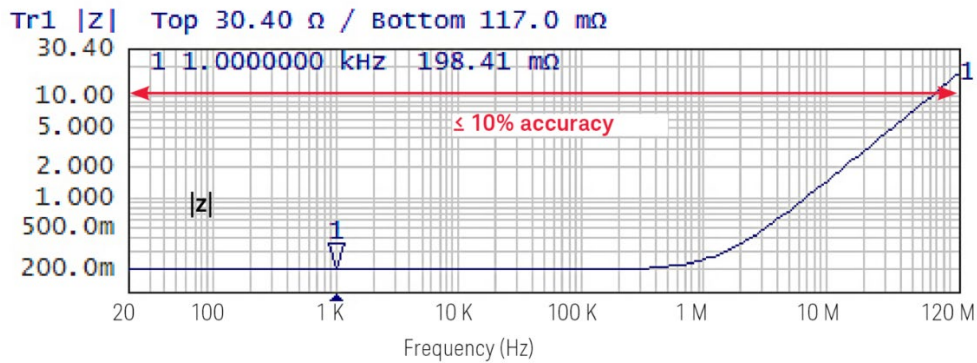

Figure 11. Frequency characteristics of a 22 nH inductor

Figure 12 shows the measurement results for  $|Z|$  and  $L_s$  using the E4990A and network analyzer for the 22 nH inductor.

The E4990A can accurately measure the low impedance of a 22 nH inductor. The measurement accuracy of the E4990A through its entire frequency range is 10% or less when measuring the impedance of a 22 nH inductor.

$|Z|$  &  $L_s$  measurements of E4990A impedance analyzer



$|Z|$  &  $L_s$  measurements of network analyzer

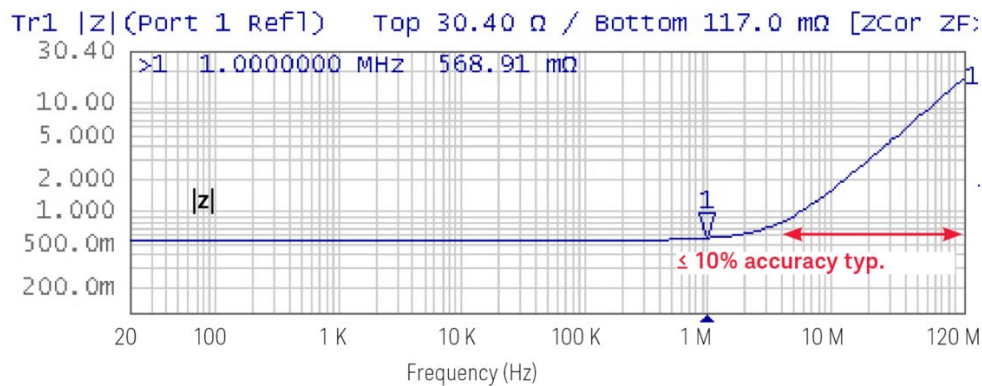

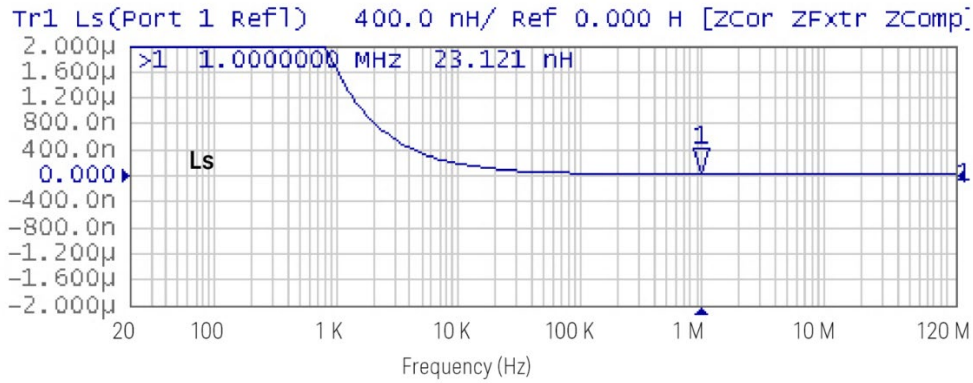

Figure 12. Measurement results example using the E4990A and network analyzer

## Low D measurement

A 10 pF SMD capacitor at 20 Hz to 120MHz, a typical impedance is shown by the dashed line in figure 13 and is measured using the E4990A and network analyzer. This section focuses on the low D measurement capability of the E4990A and network analyzer.

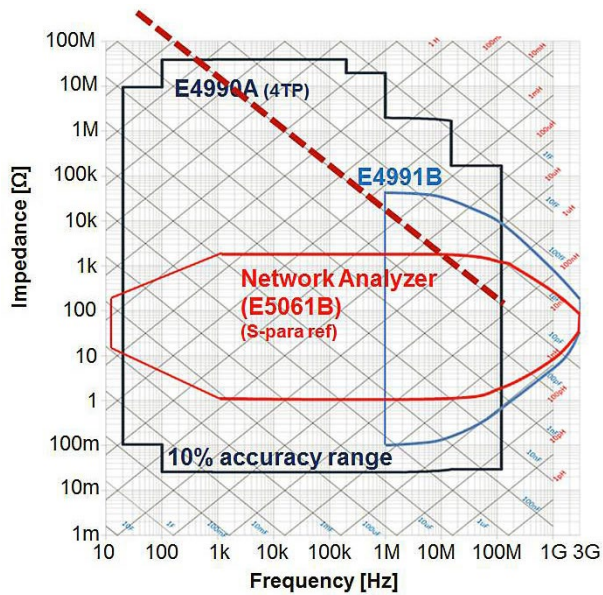

Figure 13. Frequency characteristics of a 10 pF capacitor

In the case of a low-loss (low- D) capacitor, the R-value is very small relative to the Xc-value.

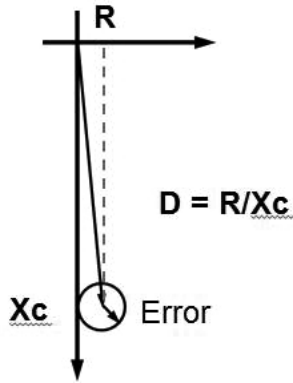
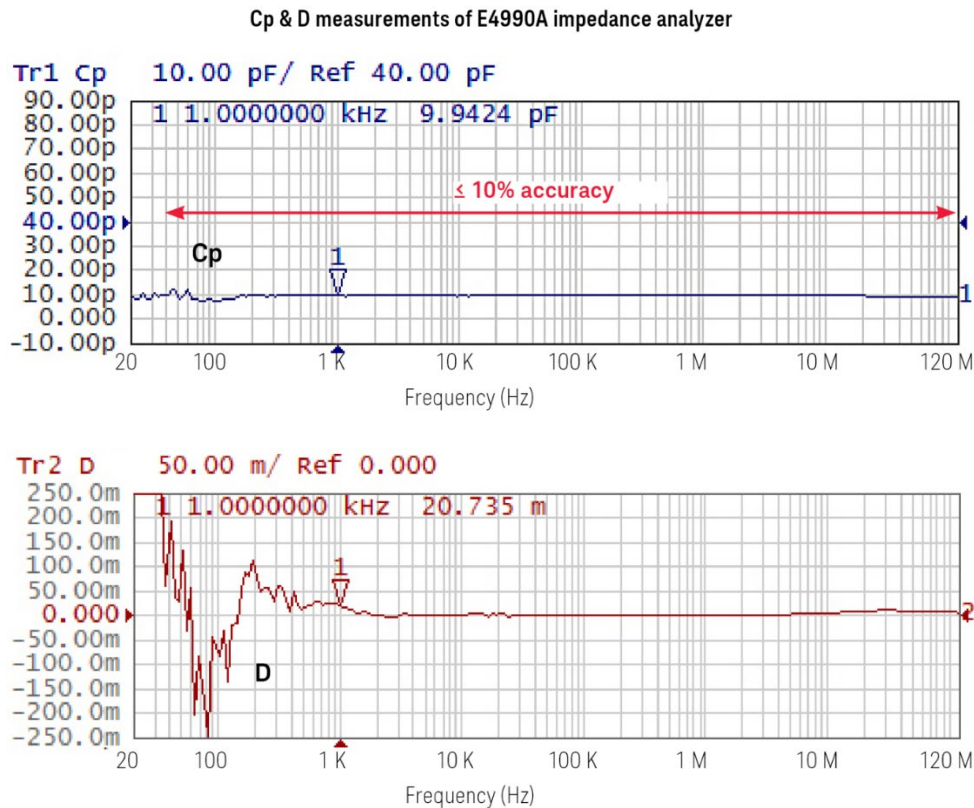

Figure 14. Expression for D

Figure 15 shows the measurement results for Cp and D using the E4990A and network analyzer for the 10 pF capacitor.

For low-D, an accurate and stable R-value measurement is required. The E4990A can accurately measure the D of the 10pF capacitor. The E4990A 10% accuracy range mostly covers the impedance of the 10 pF capacitor, and its accuracy also enables the reliable D measurement.



Cp & D measurements of network analyzer

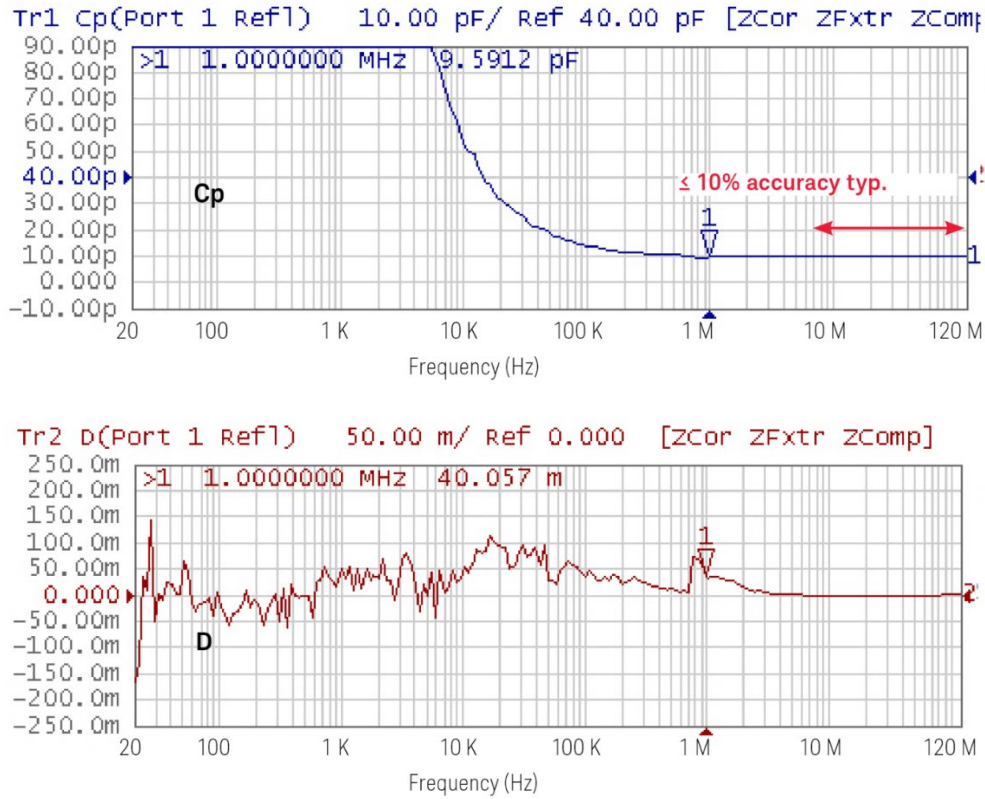

Figure 15. Measurement results example using the E4990A and network analyzer

## High Q measurement

A 22 nH SMD inductor at 1 MHz to 3 GHz, a typical impedance shown by the dashed line in figure 16 is measured using the E4991B impedance analyzer and network analyzer. This section focuses on the high Q measurement capability of the E4991B and network analyzer.

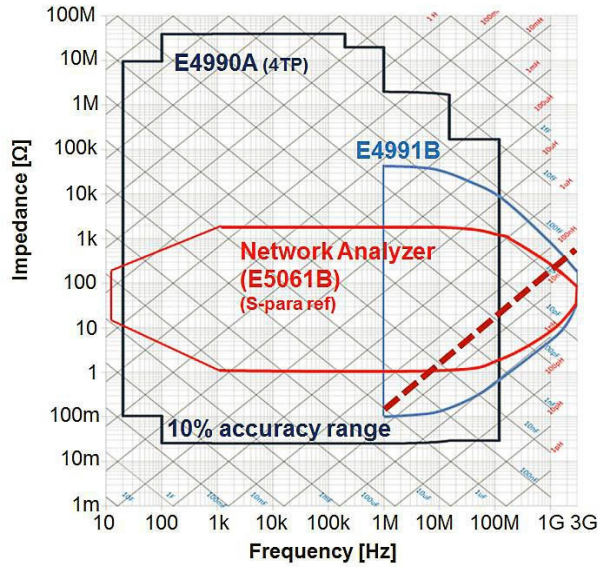

Figure 16. Frequency characteristics of a 22 nH inductor

In the case of a low-loss (high-Q) inductor, the R-value is very small relative to the XI-value.

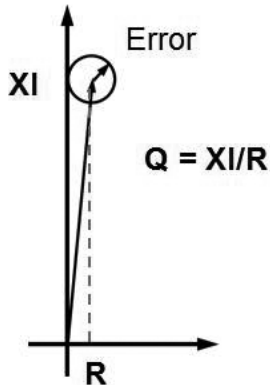

Figure 17. Expression for Q

Figure 18 shows the measurement results for Ls and Q using the E4991B and network analyzer for the 22 nH inductor.



For high-Q, an accurate and stable R-value measurement is required. The E4991B can accurately measure the Q of the 22nH inductor. The E4991B 10% accuracy range mostly covers the impedance of the 22 nH inductor, and its accuracy enables the reliable Q measurement.

The Q measurement of the network analyzer looks good seemingly. However, it is not stable even within a short-term measurement period.

### Ls & Q measurements of E4991B impedance analyzer

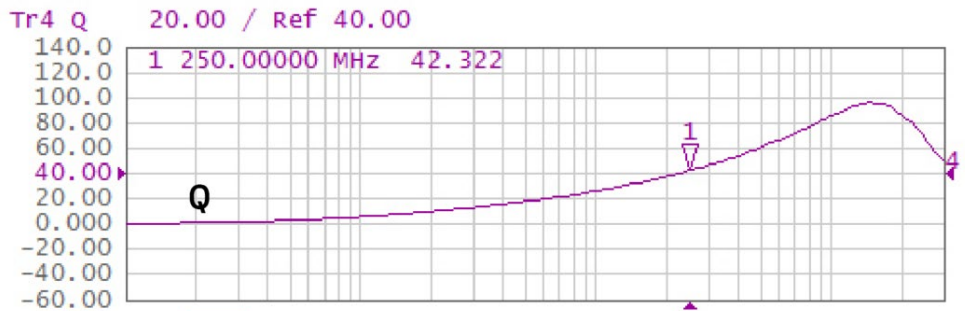
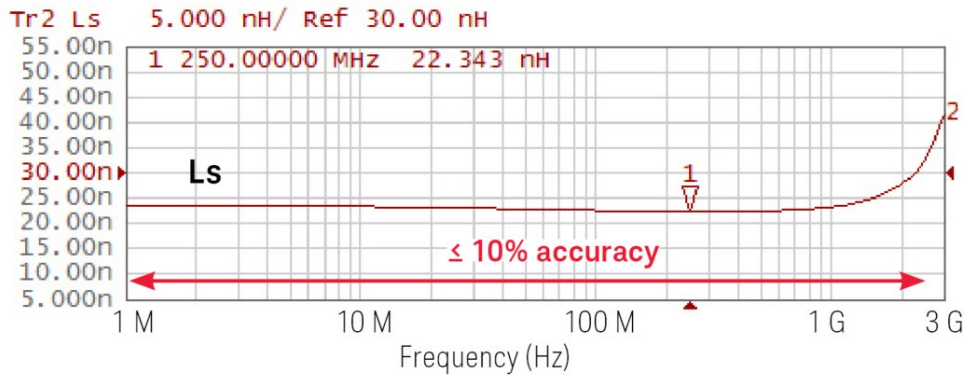

Change of Q value (after about 5 minutes)

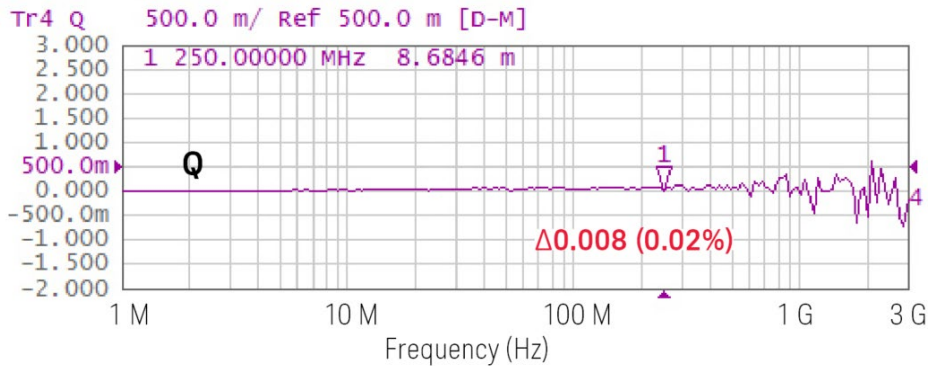

### Ls & Q measurements of network analyzer

Tr2 Ls(Port 1 Ref1) 5.000 nH/ Ref 30.00 nH [ZCor ZFxttr ZComp]

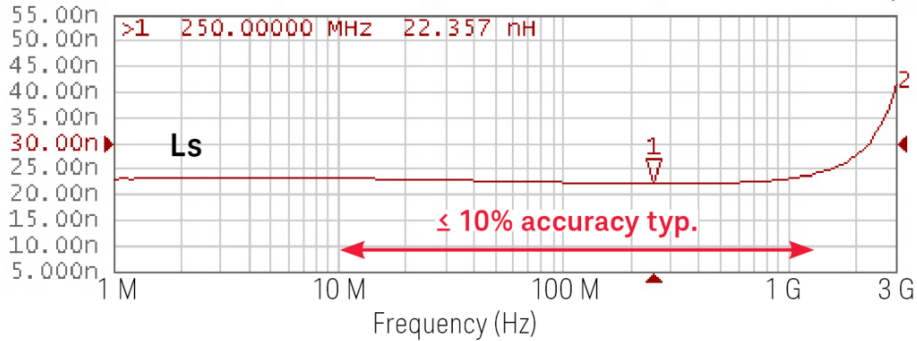

Tr4 Q(Port 1 Ref1) 20.00 / Ref 40.00 [ZCor ZFxttr ZComp]

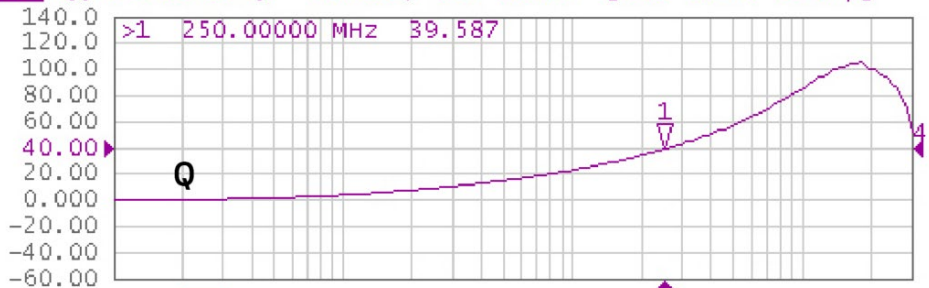

Change of Q value (after about 5 minutes)

Tr4 Q(Port 1 Ref1) 500.0 m/ Ref 500.0 m [ZCor ZFxttr ZComp D]

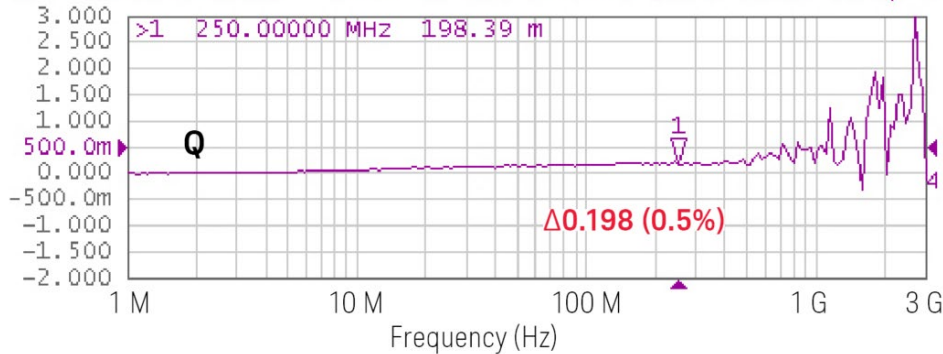

Figure 18. Measurement results example using the E4991B and network analyzer

## Measurement stability

A typical measurement routine can often take hours to complete when many sample devices are being measured for statistical analysis. The instrument must maintain accuracy continuously, to hold measurement consistency, against time lapse and in environmental temperature variances.

## Measurement stability from 20 Hz to 120 MHz

A 10 nF SMD capacitor at 20 Hz to 120 MHz, a typical impedance shown by the dashed line in figure 19 is measured using the E4990A and network analyzer. This section focuses on the measurement stability of the E4990A and network analyzer.

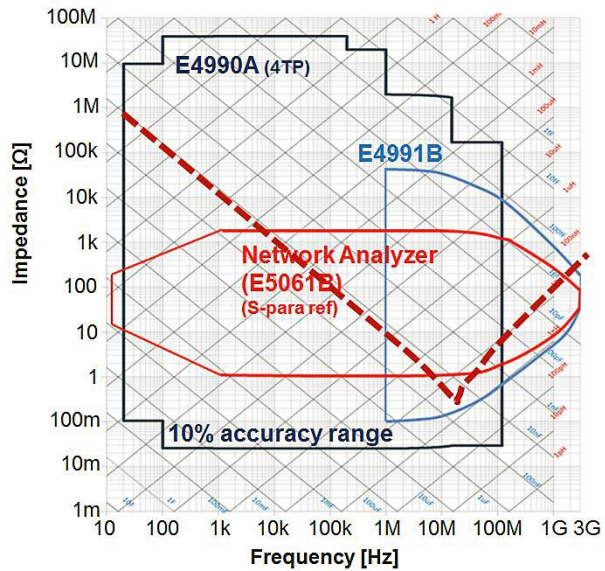

Figure 19. Frequency characteristics of a 10 nF capacitor

Figure 20 for 1  $\Omega$ , 50  $\Omega$  and 2 k $\Omega$  impedance shows a change in the measurement results of the E4990A and network analyzer for 10 nF capacitor in lapsed time of 5 hours where the room temperature was 23  $^{\circ}\text{C} \pm 5$   $^{\circ}\text{C}$ .

The results of the E4990A demonstrate measurement repeatability superior to the network analyzer. The E4990A can maintain accuracy continuously when measuring the impedance of the 10 nF capacitor.

The network analyzer requires calibration to be performed each time the instrument is powered on or a measurement setting has changed, such as test frequency. The E4990A does not require calibration.

**|Z| measurements of E4990A impedance analyzer and network analyzer**

Tr1 |Z| Top 5.180 MΩ / Bottom 36.90 mΩ

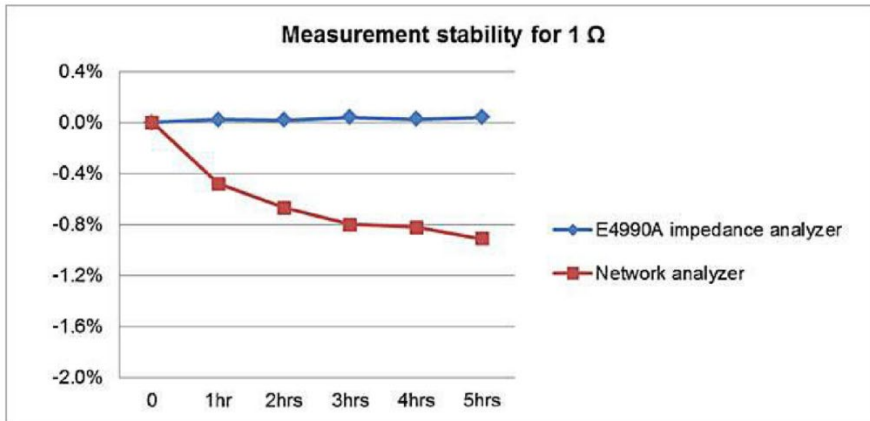
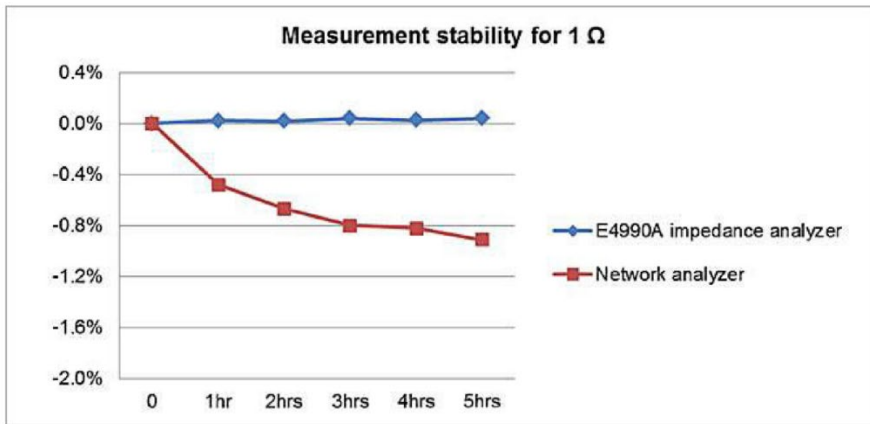
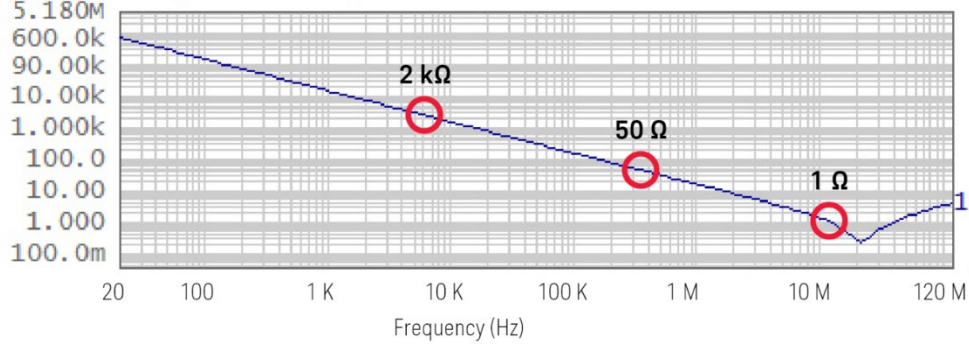

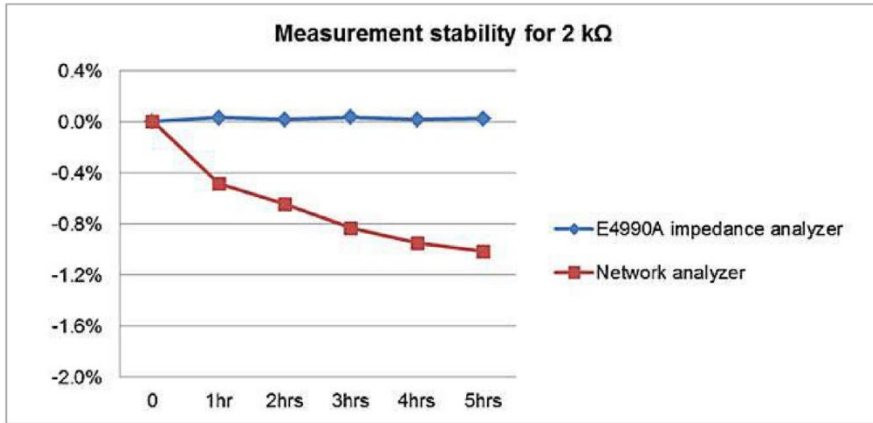

Figure 20. Measurement stability results example using the E4990A and network analyzer

### Measurement stability from 1MHz to 3 GHz

A 55 nH SMD inductor at 1 MHz to 3 GHz, a typical impedance shown by the dashed line in figure 21 is measured using the E4991B and network analyzer. This section focuses on the measurement stability of the E4991B and network analyzer.

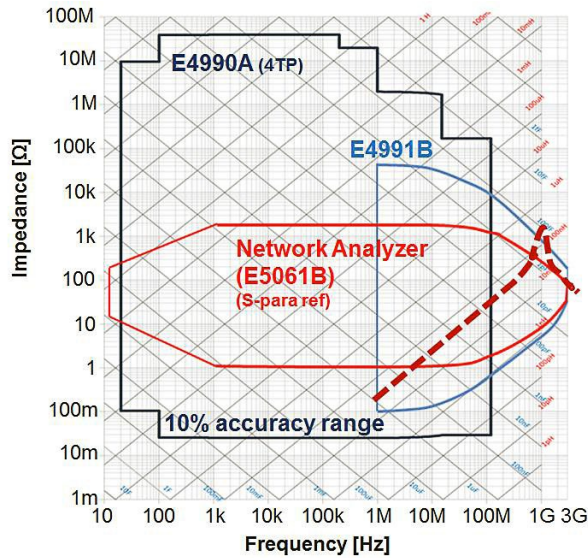

Figure 21. Frequency characteristics of a 55 nH inductor

Figure 22 for 1 Ω, 50 Ω and 2 kΩ impedance shows the change in the measurement results of the E4991B and network analyzer for a 55 nH inductor in lapsed time of 5 hours where the room temperature was 23 °C ± 5 °C.

The results of the E4991B demonstrate superior measurement repeatability as compared to the network analyzer. The E4991B can maintain continuous accuracy when measuring the impedance of the 55 nH inductor.

The network analyzer requires calibration to be performed when powered on or when a measurement setting has changed, such as test frequency. The E4991B also needs to be calibrated as well but provides more stable measurement accuracy after the calibration.

**|Z| measurements of E4991B impedance analyzer and network analyzer**

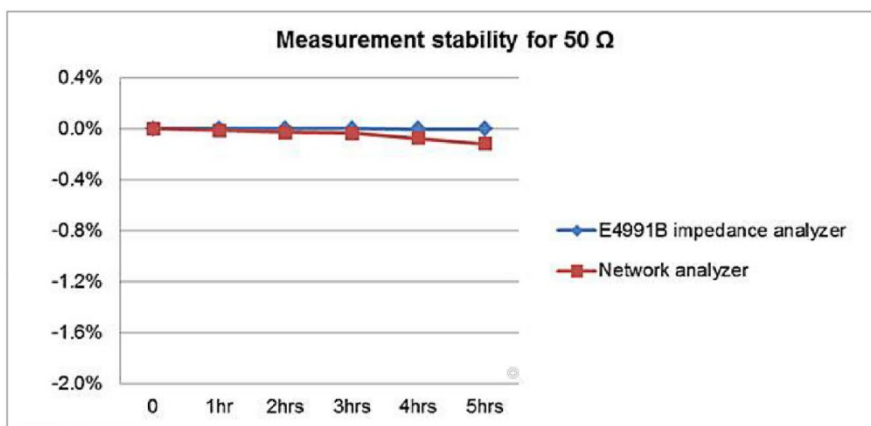
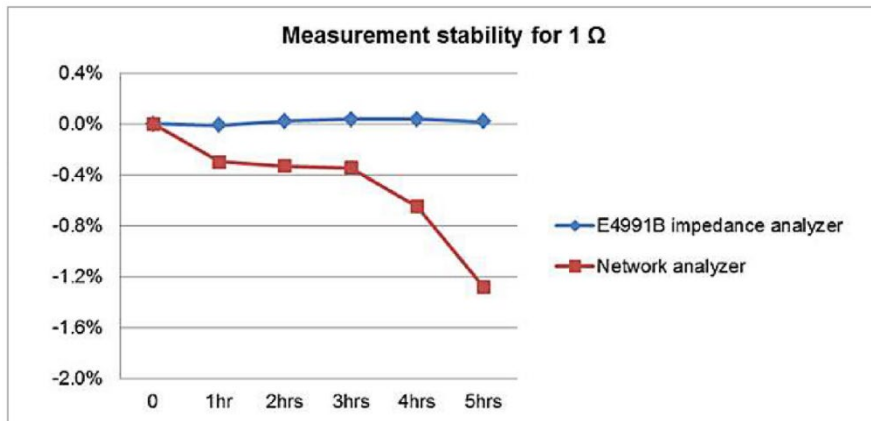
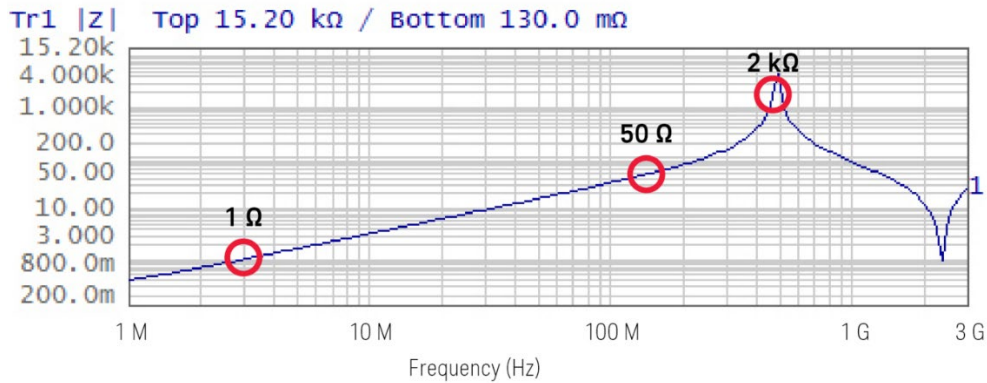

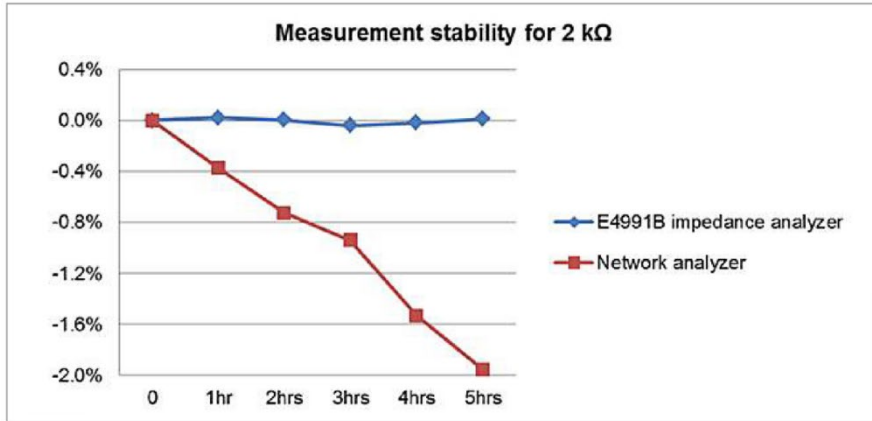

Figure 22. Measurement stability results example using the E4991B and network analyzer

# Conclusion

Keysight's impedance analyzers can measure devices away from 50  $\Omega$  with higher measurement stability than conventional network analyzers. In addition, impedance analyzers have an advantage over network analyzers in making accurate measurements of a device's parasitics and low loss factor (low D, low ESR or high Q).

When characterizing electrical devices, it is required to make accurate wide (high/low) impedance measurements, accurate high-Q/low loss measurements, and high stability measurements. Only impedance analyzers have measurement capabilities to achieve real characteristics of electrical devices from 20 Hz to 3 GHz. The E4990A extends the impedance measurement solutions to 120 MHz, and the E4991B extends to the impedance measurement solutions to 3 GHz.

## Additional Information

### Web resources

- [www.keysight.com/find/impedance](http://www.keysight.com/find/impedance)
- [www.keysight.com/find/e4990a](http://www.keysight.com/find/e4990a)
- [www.keysight.com/find/e4991b](http://www.keysight.com/find/e4991b)

### Literature

- E4990A, Brochure, 5991-3888EN
- E4990A, Data Sheet, 5991-3890EN
- E4990A, Configuration Guide, 5991-3891EN
- E4991B, Brochure, 5991-3892EN
- E4991B, Data Sheet, 5991-3893EN
- E4991B, Configuration Guide, 5991-3894EN
- LCR Meters, Impedance Analyzers and Test Fixtures, Selection Guide, 5952-1430E
- Accessories Selection Guide for Impedance Measurements, 5965-4792E
- Impedance Measurement Handbook, 5950-3000

For more information on Keysight Technologies' products, applications, or services, please visit: [www.keysight.com](http://www.keysight.com)



This information is subject to change without notice. © Keysight Technologies, 2022, Published in USA, August 8, 2022, 5992-0338EN